

Thermal Cut-off 155431 Series

One-shot Thermal Fuse with Ceramic Housing

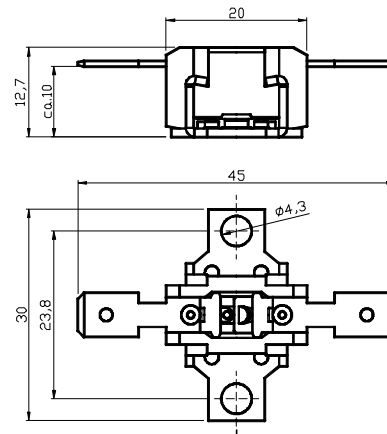
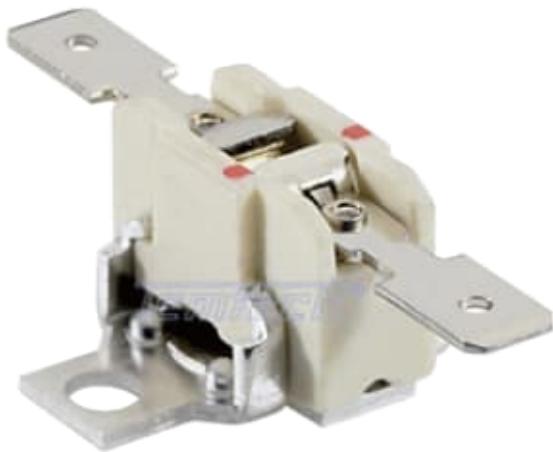

Description: Thermal fuse equipped with melt solder insert in ceramic housing. Upon reaching the preset temperature the solder will melt and break the electric circuit. It is a single-operation device that cannot be reset. The electric terminals are insulated from the base plate to enable the fuse to be fixed directly on the surface of the heated part which is to be controlled. The melt solder is placed directly on the aluminium base plate exhibiting a fast response to temperature changes. The raised sides of the insulating body offer a high degree of protection to the interior components. Due to the open frame design appropriate care is required to ensure that the interior components of the thermal fuse will not be damaged. Compliant with EN 60 691 for use in resistive circuits in normal atmosphere only.

Application: When properly used, as a safety device to break an electric circuit permanently, e.g. in coffeemakers, irons, deep fat fryers, etc.

Specifications:

Approvals:	VDE	UL
Rated voltage:	230VAC	120VAC
Rated current:	13.5A res.	15.0A res
Interrupting current:	20.3A res.	22.5A res.
Tracking resistance of base material:	PTI 250	

Temperatures:

Part-number	T _F	T _H (VDE)	T _H (UL)	T _M
240211	206°C -10K	180°C	170°C	500°C
240212	229°C -10K	205°C	195°C	500°C
240213	260°C -10K	230°C	220°C	500°C
240214	298°C -10K	260°C	250°C	500°C
240215	318°C -10K	280°C	270°C	500°C

T_F = Rated functioning temperature
T_H = Holding temperature, should not be exceeded in the application under normal operating conditions
T_M = Maximum temperature limit, must not be exceeded after tripping of fuse

Terminals: Faston terminal 6.3x0.8mm compliant with EN 61210, other terminals on request

Note: In addition to the standard design, as specified above, this thermal fuse can also be provided with a variety of electrical terminals, different angular terminal positions and various mounting options, when ordered in large quantity.

Technical specifications as stated in our data sheets are based on the results of tests carried out in the facilities of Temtech or the respective manufacturer applying standard test methods and equipment. Results obtained with different test procedures and equipments may vary. The proper adjustment of the thermostats and any other component purchased from Temtech and proof of suitability for the intended application is in the buyer's own responsibility. Temtech makes no warranty as to mismatches of any kind. As we continuously improve our products we reserve the right to change specifications without prior notice.